



Delivery of Essential Medicines by Drones in Hospital to Hospital Use

Akshay Jadhav, Rohit Madigar, Shivam Gujar, Rohit Sonawane
and Avinash Chavhan

EasyChair preprints are intended for rapid dissemination of research results and are integrated with the rest of EasyChair.

May 24, 2022

Delivery of Essential Medicines by Drones in Hospital to Hospital Use

Akshay Jadhav
Dept. Of Electrical Engineering
Nbn Sinhgad School Of Engineering,
Pune, Maharashtra, India
akshayjadhav163019@gmail.com

Shivam Gujar
Dept. Of Electrical Engineering
Nbn Sinhgad School Of Engineering,
Pune, Maharashtra, India
shivmgujar@gmail.com

Rohit Madigar
Dept. Of Electrical Engineering
Nbn Sinhgad School Of Engineering,
Pune, Maharashtra, India
rohitmadigar@gmail.com

Rohit Sonawane
Dept. Of Electrical Engineering
Nbn Sinhgad School Of Engineering,
Pune, Maharashtra, India
rohitsonawane7501@gmail.com

Avinash Chavhan
Assistant Professor
Dept. Of Electrical Engineering
Nbn Sinhgad School Of Engineering
Pune, Maharashtra, India
avinashchavhan057@gmail.com

Abstract - In this project, the use of current drone technologies is reviewed, optimized, and used to demonstrate the feasibility of medical supply delivery hospital to hospital use via UAV (unmanned aerial vehicle). This project focuses on the design of a biocompatible payload and a modified drone to accomplish medical supply delivery hospital to hospital use. The design of the payload and UAV arm mechanism must consider the safety of medical supplies, medical equipment and blood biocompatibility throughout the duration of the delivery. Multiple drone and payload design iterations were created to address the lack of medical attention in hospital to hospital use. Various designs were implemented in a prototype to create a demonstration of concept feasibility. Each design has its own parameters and components that collectively make up the payload and drone delivery system. This research paper describes, analyzes and reports experimental results of the final drone delivery and payload design, as well as the steps taken throughout the duration of the project.

This study is aimed to provide medical assistance to people through the delivery of medical supplies by unmanned drones. The use of unmanned drones is reinforced through an application that has the potential to benefit people in distant areas around the world. This study hopes to expand drone technology and the application of drones. The nature of the project and how it was conducted will be explained. Outcomes of this study include a proof of concept, the assembly of a working prototype and the evaluation of the prototype's performance. In order to make the project a success, adequate funding and resources were sought out for prototype assembly

Key Words: People safety, drone (unmanned aerial vehicle), hospital to hospital use, blood samples, medicines

1. INTRODUCTION

Unmanned craft systems were traditionally used solely by the military. Currently, the utilization of remotely piloted aircraft systems and tiny drones has distended to perform civilian tasks, such as, supporting search and rescue operations, observance weather and traffic flows, delivering goods, and after all as a platform for aerial photography. Drones are being utilized to result amendment within the environment; an honest example is in agriculture, wherever efficiencies is also created by using drones to spray fields and track crop growth patterns. However, one in all the foremost exciting areas of drone development is among the health care industries. Such applications embrace delivering medicines, vaccines, blood and alternative medical provides, that are desperately required in inaccessible areas. provide challenges are oftentimes caused by poor transport networks, extreme weather conditions, natural disasters or holdup in urban areas. Delivery by drone may well be an answer to such problems. Current pilotless craft systems (UAS) or drones is also usually classified into fixed-wing or rotary-wing aircraft. Fixed-wing UAS are a lot of efficient, have longer varies and have bigger payloads; however, rotary-wing drones commence and land vertically with the power to hover throughout flight. For drone delivery of medicines in urban situations, rotor-based drones are more applicable, whereas rural locations enjoy the greater range related to the fixed-wing aircraft

2 SPECIFICATION AND DESIGN

The studies on great practices to expand a UAV will begin this assignment work. We could expand the initial UAV after thinking about viable specifications. Then flying UAV could be connected to the digital digicam to acquire facts video that we're going to employ for AI processing. The final

degree is to create an powerful AI gadget for the medical delivery purpose

When thinking about flight manipulate gadgets for UAV implementation it's far vital to don't forget its capabilities. Capabilities which can be vital encompass gyro stabilization, cellular self-leveling, care unfastened capabilities, soaring capabilities (altitude and planar function hold), and go back domestic and waypoint navigation. These functions must be taken into consideration in order that the desires of the UAV may be met to fulfill the UAV's purpose. Additionally, the fee of the flight manipulate unit is really well worth thinking about, in particular relying at the specific price range for the advent of the UAV. Moreover, the flight manipulate unit is the maximum vital factor included at the frame of the drone.

2.1 FLIGHT CONTROLLER

A normal quadcopter comes with a four channel controller that sends instructions to the drone to have an effect on its throttle, yaw, pitch and roll. The communications frequency used 32by maximum controllers is 2.4 GHz. This is likewise the everyday frequency used for Wi- Fi connections. Though it's miles not likely that interference takes place, it is able to be some thing really well worth checking in case you are revel in communications lag or dropouts together along with your quadcopter.



2.2 FRAME

This is the modular and fairly mild weight wooden Quad Copter Frame. The foremost motives to apply this unique body are: It within reason cheap, fairly sturdy, it has a plate in the middle that serves as a strength deliver board to type matters out rather, the layout is well conceived - the body is tiny. Lots of area for receiver and manipulate board is to be had for ESCs and batteries, there may be additionally a area to be had for installing GoPro or different digital digicam configuration and a huge variety of different substitute additives and add-ons can also additionally be selected from which includes touchdown gears, jigs etc.

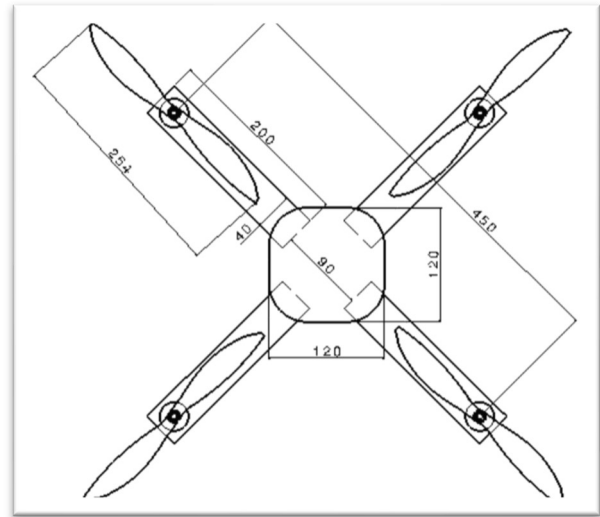

2.3 TRANSMITTER AND RECEIVER

A radio transmitter is an electrical tool for electronics and telecommunications, which creates radio waves thru an antenna. A radio common alternating modern is generated through the transmitter itself and it's miles used at the antenna. The antenna radiates radio waves whilst inspired through this alternating modern. The time period transmitter typically applies to equipment generating radio waves for communication; or radiolocation, together with radar and browser transmitters. It may be a distinct digital unit or an electrical circuit in a digital unit. Transceiver is taken into consideration a transmitter and a receiver united in a single tool. The transmitter mixes the dispatched records sign with the radio frequency sign that creates the radio waves, sometimes termed the carrier. This is what modulation is called. Radio transmitters are digital circuits transforming electric powered strength in a radio-frequency alternating modern from batteries or electricity, turning hundreds of thousands to billions of times consistent with 2d withinside the direction. The power in the sort of speedy turning modern can irradiate a conductor like electromagnetic An digital receiver is an antenna-primarily based totally circuit that uses digital filters to split the radio sign from any other sign accrued through this antenna and amplifies it to a level appropriate for similarly processing and converts it into a consumer-pleasant shape via demodulation and decoding.



1. 2.4. BATTERY

This is a LiPo 2200 mAh battery with output of 11.1 V. Weight of this battery is 170 g. The battery is composed of lithium polymer.



2.5 ESC AND MOTORS

The ESC generates three high frequency signals. These signals are produced differently but controllably with continuity, that is what keeps motor stable. Motors draw a lot of power so ESC able to source a lot of power.



Motor is used as the player vane in order homemade quadcopter you can fly and maneuver . There are so many types of motor sold in the market , but there are some things that are required of you noticed. Motor kilovolt be sorted by size , the higher the faster his kV motors also can rotate. Usually when you buy a special bike quadcopter , you will get the specifications such as : how much amperage required ESC and propeller size recommendations .



2.6. DRONE MOVEMENTS

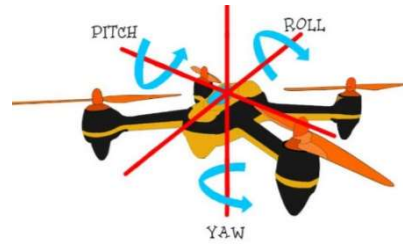

The three dimensions of the motion are pitch, yaw and roll while an object travels via a media. The motion of the yaw is a aspect-by-aspect nostril motion of the drone. The pitch axis is perpendicular to the yaw axis and is parallel to the aircraft of the wings with its beginning on the middle of gravity and directed closer to the proper wing tip. A pitch motion is the nostril of the drone upward or downwards. Rotation is referred to as roll across the forward-to-lower back axis.

3. WORKING

First , we made a frame of light weight material i.e. balsa wood. Quadcopter is a device with a intense mixture of Electronics, Mechanical and mainly on the principle of Aviation. The Quadcopter has 4 motors whose speed of rotation and the direction of rotation changes according to the user's desire to move the device in a particular direction (i.e Take-off motion, landing motion, Forward motion, Backward motion, Left motion, Right Motion.)

The rotation of Motors changes as per the transmitted signal send from the 6-Channel transmitter. The signal from microcontroller goes to ESC's which in turn control the speed of motor. The 6th channel for operating the servo moto for on and off the sprayer pump.

Before going to direction of quadcopter motor and propeller setup, lets explain a bit about the terminology used when it is flying forwards, backwards, sideways or rotating while hovering. These are known as Pitch, Roll and Yaw.

Yaw – This is the rotating of the head of the quadcopter either to right or left. It is the basic movement to spin the quadcopter. On most drones, it is the achieved by using the left throttle stick either to the left or right.

Pitch – This is the movement of quadcopter either forward or backward. Forward Pitch is achieved generally by pushing the throttle stick forward, which makes the quadcopter tilt and move forward, away from you. Backward pitch is achieved by moving the throttle stick backwards.

Roll – Most people get confused with Roll and Yaw. Roll is making the quadcopter fly sideways, either to left or right. Roll is controlled by the right throttle stick, making it fly either left of right.

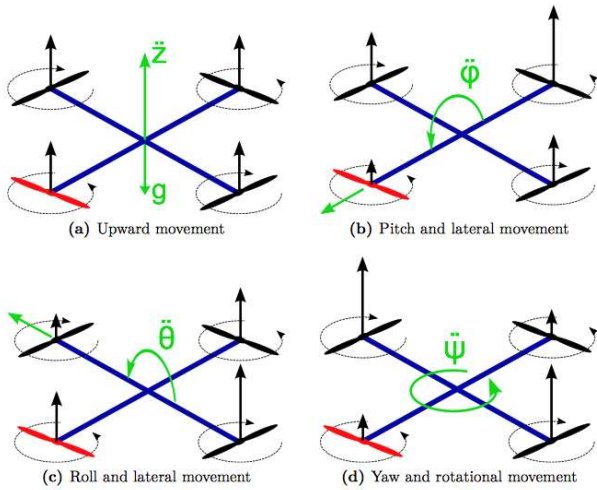
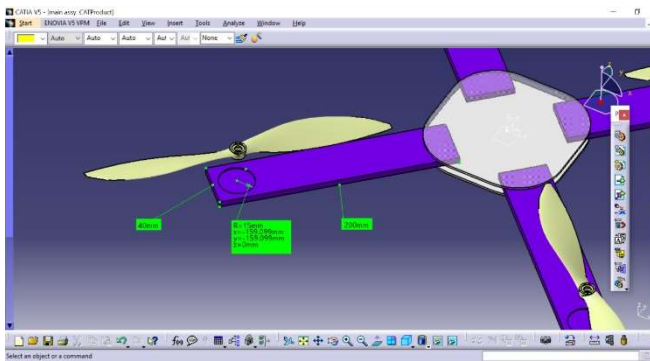

Fig. direction of quadcopter

we have taken wooden plate dimension as 200 mm because the propeller radius length itself is of 127 mm to cover the proper while rotation we have given the sufficient clearance between the propeller and Main frame of quad



Weight of frame 450 (i.e.) : 147 g

(assume as per cad model wooden density ,650 kgm³)

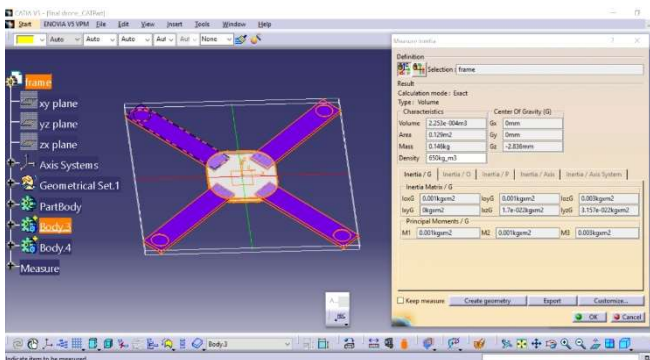

Calculation of weight of Quad-copter :

Two main important points

A. What is the total weight of your quadcopter that we have to fly

B. What is the size of your quadcopter's structure overall

As far as the total weight of the quadcopter is concerned, we can only assume it at the initial stages since we have not yet developed it. The total weight will of course include everything ranging from the frame, FC, PDB, cables, motors, ESCs, battery, payload and other components. Keep in mind that the total weight at the outset is always going to be a conservative approximation. always we can go back and update the total weight when we decide finally on the final components that we are going to use in your quadcopter.

The maximum size of the frame helps to determine the optimum propeller size.

These two important pieces of information will provide the sufficient idea regarding the thrust needed by the motors to lift the quadcopter in the air by using propellers of restricted size.

- For all selection of material and all we have studied existing benchmark available on internet so according to the help of raw data we have calculated .

We selected and frame with motor – motor distance equal to 450 mm which is sufficient to test all feature required in our project.

Assume the weight calculation ,

Weight of frame 450 (i.e.) : 147 g

Weight of one Esc : 28g

Weight of battery 2200mah : 173 g

Weight of one motor 1000kv : 57.6 g

Weight of flight control board : 50 g

Other : 8.5 g

Package : 500g

So the total weight of Quad copter comes out to be

$$\Rightarrow 147+28*4+173+57.6*4+50+8.5 +500 = 1220.9 \text{ g}$$

TOTAL QUAD WEIGHT : 1220.9 g

But for a quad copter to take fight the required thrust is twice the total flying weight. So, required thrust becomes

Thrust power required

$$\Rightarrow 1220.9*2 = 2441 \text{ g}$$

Now we got the tentative value of thrust for flying the drone is 2.4 kg

So as per our assumptions :

1 . Motor : 1000 kv motor

Specifications :

- KV(rpm/v): 1000
- Max Power: 920W
- No load power : 37 w
- Max Thrust with 1045 prop at 11 v: 800 grams
- Weight: 160 grams
- Recommended Propeller for battery: 12x4.5 for 3S battery
- Battery: 3S-5S Li-Po
- ESC(A): 30A.

Power of the motor is indicated in the motor itself

Power =37 w

Current:

By knowing required power and battery voltage, it is straightforward to calculate motor

current $I = P/V$

Where I = motor current

P = power

V = battery voltage

$= 37/11.1$

$= 3.3A$

There are 4 propellers used so $4 * 3.3 = 13.2A$

Battery runtime:

By knowing battery capacity and current consumption, we can calculate how long we can

draw that amount of current from battery. For that we will use following formula.

$T = C/I * 60$

T = time (Min)

C = battery capacity(mAh)

I = current (A)

$= (4/13.2) * 60$

$= 18.18$ Min

Variable as per current requirement.

4. RESULT

Use of unmanned aerial vehicle is one of the efficient method for delivery of medicines, vaccines and many more. The drone we made has been modified according to our need, budget and expectations from it. Mainly the weight of it is so optimized that it can carry our desired weight. This vehicle can sustain and deliver weight up to 500g.

This drone has range of 1.5 km to 2 km depending mainly upon weight and other factors. With current battery capacity this drone can sustain for 15 minutes. It can travel 2 km in approximately in 10 minutes so other tasks can be done in remaining 5 minutes.

This drone can stay stable in rough wind conditions because of GPS control system. Because of stability and optimized time factor the quality of medicines can be preserved. Because of light weight wooden frame and flight controller which we have used the drone can handled easily and efficiently.

As we are saying drone is optimized and modified which is the reason for its low price. The main advantage of this is that this drone can be repaired at lower evaluation than other drones available in markets.

5. CONCLUSION

- Delivery of medicines can be done without affecting there quality in desired distances.
- With enough optimization and modification drones can fly with desired weights.
- Travelling time can be extended by using bigger batteries and more efficient motors.
- This kind of drones can be used in normally windy areas with much efficiency.
- Prices of unmanned aerial vehicle can be optimized by using work efficient parts.
- With navigation system this drone can travel on its own in between hospitals.
- In times like lockdown or any natural calamity drones is the most efficient way in providing medicines by focusing on particular areas.
- In war situations, optimized and modified drones can become big help in rescue and providing medicines.

6. REFERENCES

- [1] Design and Development of smart UAV assistance for Firefighters[June,2021]. [www.irjet.net]
- [2] Judy E. Scott," Drone Delivery Models for Healthcare", Proceedings of the 50th Hawaii International Conference on System Sciences [2017].

- [3] E. Ackerman and E. Strickland, "Medical delivery drones take flight in East Africa", *IEEE Spectr.*, vol. 55, no. 1, pp. 34-35, 2018
- [4] B. Anbaroglu, "Drones in healthcare: An extended discussion on humanitarian logistics" in *Unmanned Aerial Vehicles in Civilian Logistics and Supply Chain Management*, Hershey, PA:IGI Global, pp. 86-114, 2019
- [5] J, Dawn. "Home - Unmanned Systems - Research Guides At National Defense University". Ndu.libguides.com. N.p., 2016. Web. 21 Apr. 2016.
- [6] Lee, Sungjae and Yosoon Choi. "Reviews Of Unmanned Aerial Vehicle (Drone) Technology Trends And Its Applications In The Mining Industry". *Geosystem Engineering (2016)*: 1- 8. Web.
- [7] Dunbar, Brian. "The Four Forces of Flight." NASA. NASA, 2003. Web. 08 Feb. 2016.
- [8] "Home Built DIY 3 DOF Flight Simulator Movement Cockpit - Mechanical." *Home Built DIY 3 DOF Flight Simulator Movement Cockpit - Mechanical*. Web. 08 Feb. 2016.